



Product Description and Specification

Catalog No 31 Description

Synthra MeIplus Reaction Loop

Synthra MeIplus Reaction Loop is a flexible and completely automated synthesis system for routine production of wide variety of [¹¹C]carbon-labeled compounds based on the generation of gas-phase [¹¹C]methyl iodide or optional [¹¹C]methyl triflate synthesis.

Automating the synthesis is simple, with easy-to-use configuration software SynthraView - the Synthra MeIplus module offers both, fully automatic and manual modes of operation.

Using in-target produced carbon dioxide, high specific activity preparations are produced ranging from 10 Ci/μmol to 24 Ci/μmol when high purity target gas is used for [¹¹C]CO₂ production.

The target gas should meet the following requirements:

- Cold carbon dioxide (CO₂) content: less than 20 ppb (part per billion)
- Cold carbon monoxide (CO) content: less than 20 ppb (part per billion)
- Cold total hydrocarbon (CH_n) content: less than 50 ppb (part per billion)

First the carbon dioxide is trapped in a stainless steel tube at -180 °C and converted to [¹¹C]methane by reduction on a Ni catalyst. The [¹¹C]methane is trapped at -120 °C on a Carboxene® column and the hydrogen is removed from the system. In a successive gas phase reaction the [¹¹C]methane is converted into [¹¹C]methyl iodide and trapped on Porapak Q in a column. Methyl iodide is ready for release after only 7 min starting from trapping the [¹¹C]carbon dioxide. The yield for the [¹¹C]methyl iodide formation is better than 50 %.

Up to **15** sequential methyl iodide preparations are possible from a single box set-up. The [¹¹C]methyl iodide can be converted to [¹¹C]methyl triflate in an additional triflate oven. The [¹¹C]methyl iodide can also be used for solid support heterogeneous reactions for the synthesis of e. g. [¹¹C]choline, [¹¹C]methionine or can be directed into the reaction loop for homogeneous reactions.

Details of the synthesis system:

The module has 5 reagent vials with dead volume free connections to the valves enabling multistep radio synthesis procedures.

An integrated semi-prep Radio-HPLC with a flow of 0-40ml/min with UV and radioactivity detector for product separation with two separated solvent supply reservoirs is built-in.

The module has an additional solid phase extraction (SPE) unit, for the formulation of an injectable solution, with isotonicity and pH adjustment and sterilization by filtration for a reliable production and formulation of [¹¹C]compounds with high specific activity.

The reaction loop module has six radioactivity detectors to measure the radioactivity in different positions and to determine the activity of the final radiopharmaceutical preparation.

The module also contains filter integrity test capability according to GMP. After filtration of the final formulated radiopharmaceutical product, an automated pressure hold test according to GMP is done at the sterile filter. The measuring procedure is monitored and graphically documented.

The synthesis unit has a chemically inert vacuum pump with end vacuum of < 5 hPa (5 mbar).

All wetted components are chemically inert, simplifying maintenance and protecting the final product.

A portable PC for controlling the synthesizer with min. 320 GB hard disk drive, 4 GB RAM, CD/DVD reading/writing, 15" screen and LAN port is included. The control hardware is implemented in the synthesizer. The synthesizer is controlled via TCP/IP from the provided notebook.

The synthesizer can be operated either fully automated controlled by software using time lists or by manual operation of the automated system. The automated as well as the manual operation is performed via graphical user interface.

The synthesizer has program lists for 6 different radiopharmaceuticals already built-in. New sequences can be created easily and tested by graphical simulation prior to the operation of the new sequence. The integrated program lists can be used as templates for the creation of new time lists for new radiopharmaceutical productions.

The synthesizer has a built-in cleaning program.

The machine runs with a data logging procedure. All manual or automated operations are separately recorded. The synthesizer provides a synthesis report which includes the preparations steps, the recorded data channels, the yield of the synthesis and the specific activity of the synthesized tracer.

The software generates full GLP conform production documentation including data logging capability. The documentation report includes preparation steps, the graphical trending of the up to 18 channels, radioactivity, temperature and pressure, the radiochemical yield and the specific activity of the labeled radiopharmaceutical. The software has built-in functions e. g. for the preparation and printing of production reports. The software is in full compliance with GMP/GLP guidelines.

A copy of the SynthraView software is provided.

Features:

- Simple creation of user-defined synthesis methods
- Eight heating zones, four with cooling capabilities (-196 °C – 800 °C)
- Closed reaction loop with integrated cooling (-196 °C – 220 °C) to reduce synthesis time
- Three electronic flow controllers
- One leak detector
- Built-in preparative Radio/UV-HPLC system (40 mL/min = max. flow) for product collection
- Six shielded radiation detectors for in-process feedback
- Three small (1 - 3 mL) and two large (10 - 15 mL) volume glass vials for reagents
- Chemically inert valves with small dead volume (< 35 µL), 5 bar rated
- Chemically inert vacuum pump with end vacuum of < 5 hPa (5 mbar)
- Cooling trap with liquid nitrogen to collect radioactive volatiles compounds
- Automatic pneumatic injection valve with a 0.5 to 1.5 mL sample loop
- The unit as well as the software are easy to set up and operate
- The synthesizer has program lists for 6 different radiopharmaceuticals
- Automated cleaning
- Electronic control and data collection system for 18 channels embedded
- cGMP compliance complete logbook for cGMP documentation
- Control via TCP/IP
- Password protected access to software
- Software (Windows 7, SynthraView), computer and mouse included



Synthra MeIplus reaction loop

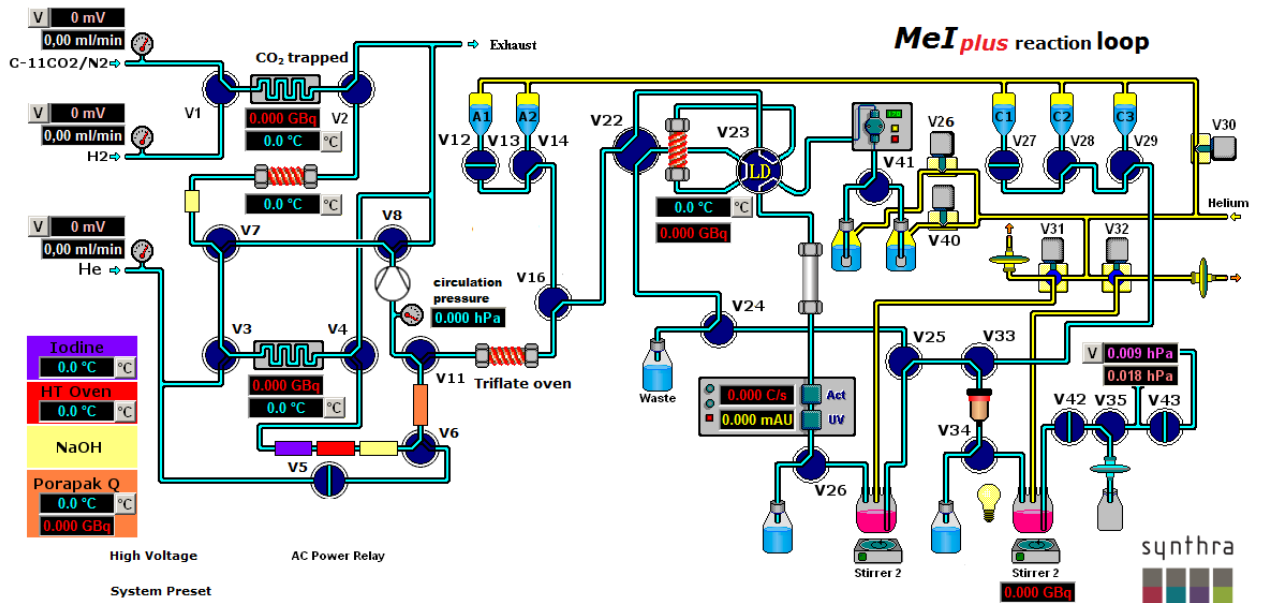

Synthra MeIplus reaction loop graphical user interface

Examples for producible [¹¹C]compounds

¹¹ C]Radiotracer	Target	Application
Raclopride	D ₂ dopamine receptors	Neuropsychiatric disorders
DASB	SERT receptors	Neuropsychiatric disorders
Flumazenil	Benzodiazepine receptor	Neurodegenerative diseases
Methionine	Amino acid transporter	Brain, head and neck, lung and breast cancer, lymphomas
Choline	Choline kinase	Brain tumors, prostate, lung and esophageal cancer
PIB	β amyloid plaque	Alzheimer's Disease

Specifications:

Yields: >50 % for [¹¹C]CH₃I in less than 7 min

Total activity is depending on the produced [¹¹C]CO₂, which means it depends on the cyclotron.

Yields and specific activity of labeled [¹¹C]tracers are depending on use of proper technique and appropriate reagents.

Time for sequential synthesis	Depends on the selected synthesis
Number of consecutive [¹¹ C]CH ₃ I synthesis	10, then exchange of NaOH trap
Dimensions	53 × 45 × 48 (w × d × h in cm)
Weight	Approx. 42 kg

Hot Cell (minimum size) 65 × 55 × 55 (w × d × h in cm)

Utilities

Compressed air	4 - 8 bar 6 mm O.D.
Compressed He	Purity 6.0 (99.9999%) 3 - 5 bar, 1/8" O.D.
Compressed H ₂	Purity 5.6 (99.9996 %) 3 - 5 bar, 1/16" O.D.
Target gas connection	1/16" or 1/8" O.D.