



Product Description and Specification

Catalog No 4

Description

Synthra RNplus Research

Synthra RNplus Research is a flexible and completely automated radio synthesis system for routine production of wide variety of [¹⁸F]fluorine labeled compounds by nucleophilic substitution, with automated sequences for compounds like [¹⁸F]F-DOPA, [¹⁸F]FDG, [¹⁸F]FLT, [¹⁸F]FHBG, [¹⁸F]FDDNP, [¹⁸F]MISO, [¹⁸F]FAZA and [¹⁸F]Fluorocholine. For any other [¹⁸F]labeled customer compounds an automated sequence will be generated. The synthesis unit includes all components needed for preparation, labeling, purification and formulation of [¹⁸F]fluorine labeled compounds. Automating the synthesis is simple, with the easy-to-use configuration software SynthraView, the Synthra RNplus Research module offers both, fully automatic and manual modes of operation.

The radio synthesis system has a dedicated sub system for the recovery and collection of [¹⁸O]H₂O for the purification of the cyclotron produced [¹⁸F]fluoride. The target activity is measured with a separated detector.

There are two synthesis reaction vessels and one column oven for a solid support reaction zone, allowing multiple step (homogenous and heterogeneous) synthesis reactions. The reaction vessels include PID controlled heaters for a temperature range between -50 °C and 250 °C. The optimized heating and cooling from 20 °C to 100 °C takes only 1 minute. A collection pipe for the exhausted cooling gas is provided. Each reaction vessel is equipped with a pressure transducer, a temperature sensor and a radioactivity detector.

The synthesis system is equipped with:

- 16 reagent vials with dead volume free connections to the valves enabling multistep radio synthesis procedures
- 8 cartridge holder for in-process purification steps
- 5 mL dispenser for transferring the reaction mixture to the HPLC injection valve
- A automatic pneumatic injection valve
- A built-in Radio-HPLC with quaternary gradient pump, variable wavelength detector, column switching valve, two HPLC columns and two solid phase extraction (SPE) for one in-process and the final HPLC purification step, isotonicity and pH adjustment and sterilization by filtration for reliable production and formulation of fluoride compounds with high specific activity.
- A built-in detector to determine the activity of the final radiopharmaceutical preparation
- A liquid nitrogen cooling trap for the collection of radioactive volatiles

The module also contains filter integrity test capability according to GMP. After filtration of the final formulated radiopharmaceutical product, an automated pressure hold test according to GMP is done at the sterile filter. The measuring procedure is monitored and graphically documented.

The synthesis unit has a chemical inert vacuum pump with end vacuum of < 5 hPa (5 mbar). For the collection of radioactive volatiles the synthesis unit is equipped with a liquid nitrogen cooling trap.

All wetted components are chemically inert, simplifying maintenance and protecting the final product.

A portable PC for controlling the synthesizer is included. The control hardware is implemented in the synthesizer. The synthesizer is controlled via TCP/IP from the provided notebook.

The synthesizer can be operated either fully automated, controlled by software using time lists or by manual operation of the automated system. The automated as well as the manual operation is performed via graphical user interface.

New synthesis sequences can be created easily and tested by graphical simulation prior to the operation of the new sequence. The existing program lists can be used as templates for the creation of new time lists for new radiopharmaceutical productions. The synthesizer has a built-in cleaning program.

The machine runs with a data logging procedure. All manual or automated operations are separately recorded. The software generates full GLP conform production documentation including data logging capability. The documentation report includes preparation steps, the graphical trending of up to 18 channels, radioactivity, temperatures and pressure, the radiochemical yield and the specific activity of the labeled radiopharmaceutical. The software has built-in functions e. g. for the preparation and printing of production reports. It also offers a graphical user interface for graphical display and trending of data. The software is in full compliance with GMP/GLP guidelines.

A copy of the SynthraView software is provided.

Features:

- Simple creation of user-defined synthesis methods
- Three heating zones, all with cooling capabilities (-50 °C to 250 °C)
- Two closed glassy carbon reaction vessels, 7 mL conical shape for 150 µL reaction volume and one 11 mL, with integrated cooling (-50 °C to 250 °C) to reduce synthesis time
- Built-in preparative quaternary gradient Radio/UV-HPLC system (40 mL/min = max. flow)
- Variable UV/Vis detector
- Two HPLC fraction collecting vials for in-process HPLC purification
- Five shielded radiation detectors for in-process feedback
- Two pressure transducers to monitor the pressure of the reaction vessels
- [¹⁸O]Water recovery capability
- 8 small (3 mL) and 8 large (15 mL) volume glass vials for reagents
- Chemically inert valves with small dead volume (35 µL), 5 bar rated
- Chemically inert vacuum pump, end pressure <5 hPa, (<5 mbar)
- Liquid nitrogen trap for radioactive volatiles and to protect built-in vacuum pump
- Automatic 5 mL dispenser to transfer the reaction mixture into the HPLC injection valve
- Automatic pneumatic injection valve with 3 mL or 5 mL sample loop
- Built-in filter integrity test for final filtration step with additional pressure transducer
- Easy to set up and operate
- Automated cleaning program
- Compliance with GMP/GLP guidelines
- Control via TCP/IP
- Password protected access to software
- Software (Windows 7, SynthraView), computer and mouse included



Synthra RNplus Research Research

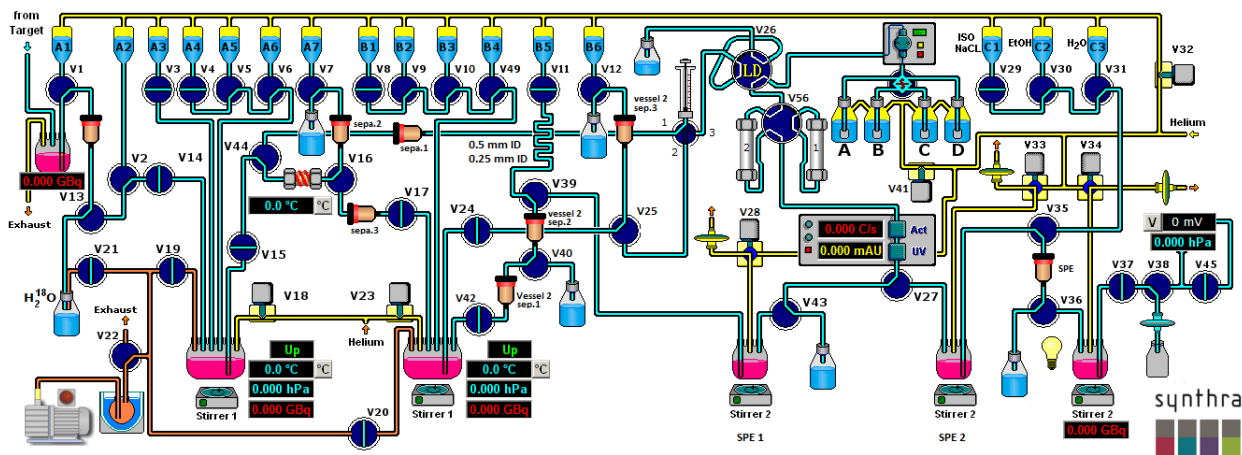

Synthra RNplus Research Research graphical user interface

Examples for [¹⁸F]compounds

[¹⁸F]Radiotracer	Target	Application
FLT	DNA proliferation	Tumor cell proliferation
FDDNP	β -Amyloid protein	Alzheimer disease
Flumazenil	Benzodiazepine receptor	Epileptic foci
FHBG	Gene expression	Cancer gene therapy
Fluorocholine	Choline kinase	Prostate I tumor
F-Miso	Hypoxic cell marker	Head and neck cancer
F-Dopa	D ₂ dopamine receptors	Neurodegenerative diseases
FDG	Glucose metabolism	Tumor diagnostic

Specifications:

**Yields, setup time and synthesis time will vary depending on the biomarker produced.
Yields are dependent on use of proper technique and appropriate reagents.**

Dimensions **64 × 48 × 49 cm (w × d × h)**

Weight Approx. 42 kg

Hot Cell (minimum size) 75 cm × 55 cm × 55 cm (w × d × h)

Utilities

Compressed air 4 - 8 bar
6 mm O.D.

Compressed helium, nitrogen or argon Purity 5.6 (99.9996 %)
3 - 5 bar, 1/8" O.D.