



Product Description and Specification

Catalog No 5

Description

Synthra MeI

Synthra MeI is a flexible and completely automated synthesis system for routine production of [¹¹C]methyl iodide based on the generation by gas-phase synthesis.

Automating the synthesis is simple, with easy-to-use configuration software SynthraView - the Synthra MeI module offers both, fully automatic and manual modes of operation.

Using in-target produced [¹¹C]carbon dioxide, high specific activity preparations are produced ranging from 25 Ci/μmol to 30 Ci/μmol depending on the purity of the used target gas. Up to 15 sequential [¹¹C]methyl iodide preparations are possible from a single box set-up.

The software generates production documentation - collecting up to 18 different parameters in-process - and offers a graphical user interface for graphical display and trending of data.

First the carbon dioxide is trapped in a stainless steel tube at -180 °C and converted to [¹¹C]methane by reduction on a Ni catalyst. Then the [¹¹C]methane is trapped at -140 °C on a Carbosphere® column and the hydrogen is removed from the system. In a successive gas phase reaction the [¹¹C]methane is then converted into [¹¹C]methyl iodide and trapped on Porapak® Q in a steel column. [¹¹C]Methyl iodide is ready for release after only 7 min starting from trapping the [¹¹C]carbon dioxide. The yield for the [¹¹C]methyl iodide formation is better than 50 % non-decay corrected.

All wetted components are chemically inert, simplifying maintenance and protecting the final product.

The synthesis unit has a built-in detector to determine the activity of the final radiopharmaceutical preparation.

The synthesis unit has a chemical inert vacuum pump with end vacuum of 5 mbar.

A portable PC for controlling the synthesizer with min. 320 GB hard disk drive, 4 GB RAM, CD/DVD reading/writing, 17" screen and with LAN port is included. The control hardware is implemented in the synthesizer. The synthesizer is controlled via TCP/IP from the provided notebook.

The synthesizer can be operated either fully automated, controlled by software using time lists or by manual operation of the automated system. The automated as well as the manual operation performs via graphical user interface.

The machine runs with a data logging procedure. All manual or automated operations are separately recorded.

The software generates full GLP conform production documentation including data logging capability. The documentation report includes preparation steps, the graphical trending of the up to 18 channels, radioactivity, temperature and pressure, the radiochemical yield and the specific activity of the labeled radiopharmaceutical. The software has built in functions e. g. for the preparation and printing of production reports. It also offers a graphical user interface for graphical display and trending of data. The software is in full compliance with GMP/GLP guidelines.

A copy of the SynthraView software is provided.

Features:

- Simple creation of user-defined synthesis variations
- Six heating zones, three with cooling capabilities (-180 °C – 800 °C)
- Compact built-in high temperature oven for 800 °C
- Three electronic flow controller for highly defined gas flow rates
- One leak tester
- Three shielded radiation detectors for in-process feedback
- Chemically inert valves with small dead volume (35 µL)
- Easy to set up and operate
- Automated cleaning
- Electronic control and data collection system for 18 channels embedded
- cGMP compliance complete logbook for cGMP documentation
- Control via TCP/IP
- Password protected access to software
- Software (Windows 7, SynthraView), computer and mouse included



Synthra MeI

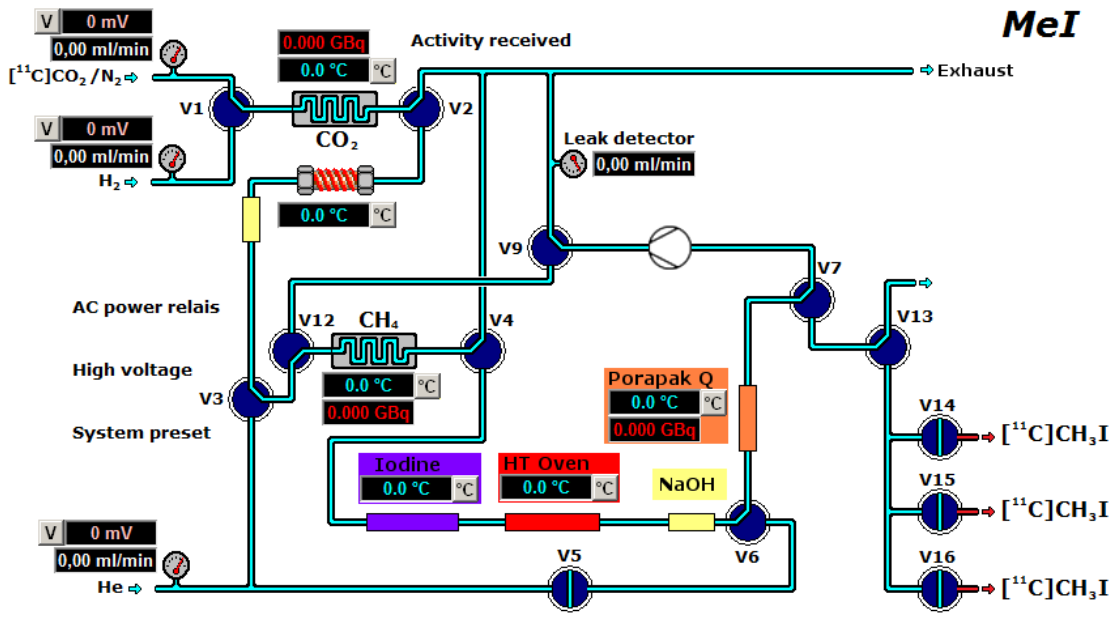

Synthra MeI graphical user interface

[¹¹C] labeling compound

Radiotracer
[¹¹C]CH₃I

Target
GPextent

Application
[¹¹C]labeling

Specifications:

Yields:	> 50 % for [¹¹ C]CH ₃ I in less than 7 min
Maximum [¹¹ C]CO ₂ starting activity	370 GBq
Radiochemical purity for [¹¹ C]-CH ₃ I	> 99 %

Yield and specific activity of labeled [¹¹C]CH₃I is dependent on use of proper technique and appropriate reagents.

Time for sequential synthesis	< 7 minutes
Number of consecutive [¹¹ C]CH ₃ I synthesis	10, than changing the NaOH traps
Dimensions	30 cm × 45 cm × 44 cm (w × d × h)
Weight	Approx. 25 kg

Hot Cell (minimum size)

50 cm × 50 cm × 50 cm (w × d × h)

Utilities

Compressed air	4 - 8 bar 6 mm O.D.
Compressed He	Purity 6.0 (99.9999 %) 3 - 5 bar, 1/8" O.D.
Compressed H ₂	Purity 5.6 (99.9996 %) 3 - 5 bar, 1/8" O.D.
Target gas connection	1/8" O.D.

Synthra GmbH reserves the right to modify the information contained herein without prior notice.
Copyright © 2013 Printed in the EU Rev 1.0