



## Product Description and Specification

Catalog No 3r Description

### Synthra MeIplus Research

**Synthra MeIplus Research is a flexible and completely automated synthesis system for routine production of wide variety of [<sup>11</sup>C]carbon-labeled compounds based on the generation of gas-phase [<sup>11</sup>C]methyl iodide or optional [<sup>11</sup>C]methyl triflate synthesis.** Automating the synthesis is simple, with easy-to-use configuration software SynthraView - the Synthra MeIplus Research module offers both, fully automatic and manual modes of operation.

Using in-target produced carbon dioxide, high specific activity preparations are produced ranging from 370 GBq/μmol (10 Ci/μmol) to 925GBq/μmol) (25 Ci/μmol when high purity target gas is used for [<sup>11</sup>C]CO<sub>2</sub> production.

#### The target gas should meet the following requirements:

- Cold carbon dioxide (CO<sub>2</sub>) content: less than 20 ppb (part per billion)
- Cold carbon monoxide (CO) content: less than 20 ppb (part per billion)
- Cold total hydrocarbon (CH<sub>n</sub>) content: less than 50 ppb (part per billion)

First the carbon dioxide is trapped in a stainless steel tube at -180 °C and converted to [<sup>11</sup>C]methane by reduction on a Ni catalyst. The [<sup>11</sup>C]methane is trapped at -120 °C on a Carbosphere® column and the hydrogen is removed from the system. In a successive gas phase reaction the [<sup>11</sup>C]methane is converted into [<sup>11</sup>C]methyl iodide and trapped on Porapak Q in a column. Methyl iodide is ready for release after **only 7 min** starting from trapping the [<sup>11</sup>C]carbon dioxide. The yield for the [<sup>11</sup>C]methyl iodide formation is better than **50%**.

Up to **10** sequential methyl iodide preparations are possible from a single box set-up. The [<sup>11</sup>C]methyl iodide can be converted to [<sup>11</sup>C]methyl triflate in an additional triflate oven. The [<sup>11</sup>C]methyl iodide or can also be used for solid support heterogeneous reactions for the synthesis of e. g. [<sup>11</sup>C]choline, [<sup>11</sup>C]methionine or can be directed into the reaction vessel for homogeneous reactions.

Nine reagent vials with dead volume free connections to the valves enabling multistep radio synthesis procedures. All wetted components are chemically inert, simplifying maintenance and protecting the final product.

The system contains two closed reaction vessels, what enable multistep reactions. Both reaction vessels contain heating and cooling function (-196 °C – 250 °C) to reduce the reaction time.

The module provides an integrated quaternary gradient Radio-HPLC with a variable wavelength detector. The HPLC is assembled with two columns and a switching valve which allows in-process purification steps for different tracer by selecting the column. After HPLC separation a solid phase extraction (SPE) is integrated for a reliable production and formulation of isotonic injectable solutions of [<sup>11</sup>C]compounds with high specific activity.

The synthesis unit has a built-in detector to determine the activity of the final radiopharmaceutical preparation.

The module also contains filter integrity test capability according to GMP. After filtration of the final formulated radiopharmaceutical product, an automated pressure hold test according to GMP is done at the sterile filter. The measuring procedure is monitored and graphically documented.

The synthesis unit has a chemically inert vacuum pump with end vacuum of < 5 hPa (5 mbar) and a liquid nitrogen cooling trap for the collection of radioactive volatiles and for protection of the vacuum pump.

A portable PC for controlling the synthesizer with min. 320 GB hard disk drive, 4 GB RAM, CD/DVD reading/writing, 15,6" screen and LAN port is included. The control hardware is implemented in the synthesizer. The synthesizer is controlled via TCP/IP from the provided notebook.

The synthesizer can be operated either fully automated controlled by software using time lists or by manual operation of the automated system. The automated as well as the manual operation is performed via graphical user interface.

The synthesizer has program lists for 6 different radiopharmaceuticals already built-in. New sequences can be created easily and tested by graphical simulation prior to the operation of the new sequence. The integrated program lists can be used as templates for the creation of new time lists for new radiopharmaceutical productions. The synthesizer has also a built-in cleaning program.

The machine runs with a data logging procedure. All manual or automated operations are separately recorded. The synthesizer provides a synthesis report which includes the preparations steps, the recorded data channels, the yield of the synthesis and the specific activity of the synthesized tracer.

The software generates full GLP conform production documentation including data logging capability. The documentation report includes preparation steps, the graphical trending of the up to 18 channels, radioactivity, temperature and pressure, the radiochemical yield and the specific activity of the labeled radiopharmaceutical. The software has built-in functions e. g. for the preparation and printing of production reports. The software is in full compliance with GMP/GLP guidelines.

A user administration with four levels of authorizations is included.

A copy of the SynthraView software is provided.

**Features:**

- Simple creation of user-defined synthesis methods
- Ten heating zones, six with cooling capabilities (-196 °C - 800 °C )
- Two closed reaction vessel with integrated cooling (-196 °C - 250 °C) to reduce synthesis time
- Three electronic flow controllers
- Four electronic pressure sensors
- Built-in preparative Radio/UV-HPLC system (40 mL/min = max. flow) for product collection
  - Variable wavelength detector
  - Quaternary gradient
  - Two HPLC columns for in-process and final purification
  - Automatic pneumatic valve to select the HPLC column
- Eight shielded radiation detectors for in-process feedback
- Seven small (1 - 3 mL) and four large (10 - 15 mL) volume glass vials for reagents
- Chemically inert valves with small dead volume (< 35 µL), 5 bar rated
- Chemically inert vacuum pump with end vacuum of < 5 hPa (5 mbar)
- Cooling trap with liquid nitrogen to collect radioactive volatiles compounds
- Automatic pneumatic injection valve with a 0.5 to 1.5 mL sample loop
- The unit as well as the software are easy to set up and operate
- The synthesizer has program lists for 6 different radiopharmaceuticals
- Automated cleaning
- Electronic control and data collection system for 18 channels embedded
- cGMP compliance complete logbook for cGMP documentation
- Control via TCP/IP
- Password protected access to software
- Four level user administration control of the machine
- Software (Windows 7, SynthraView), computer and mouse included

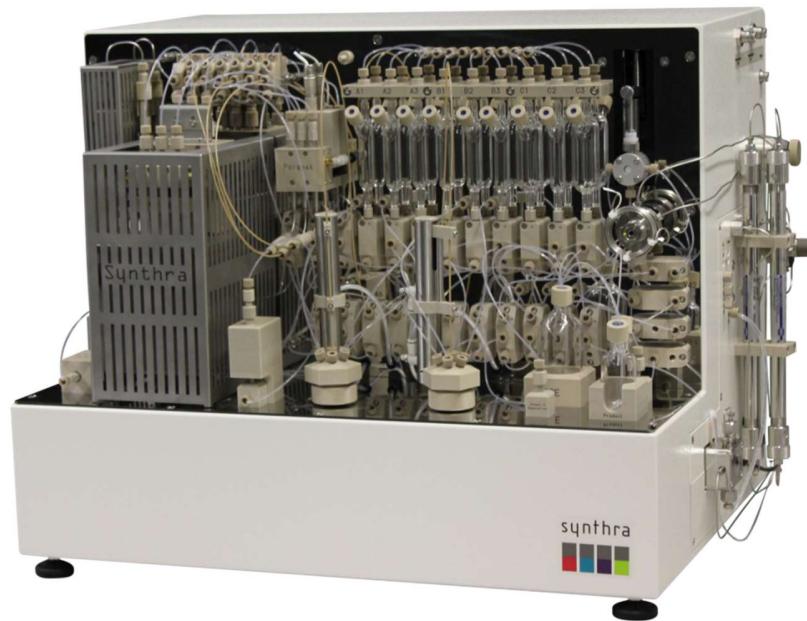

Synthra MeIplus Research

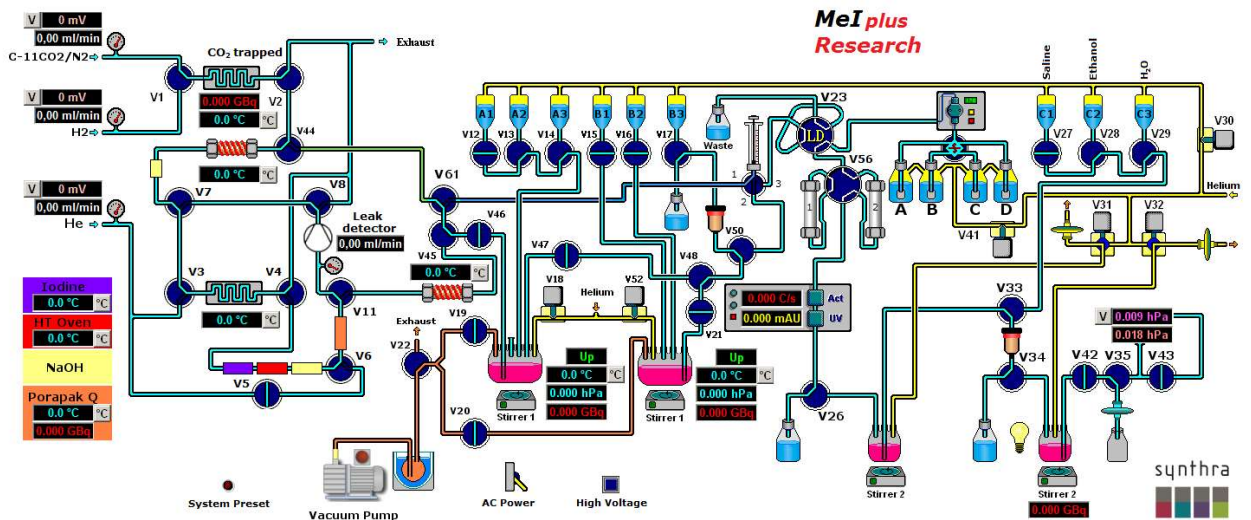

Synthra MeIplus Research graphical user interface

## Examples for [<sup>11</sup>C]compounds

<b>[<sup>11</sup>C]Radiotracer</b>	<b>Target</b>	<b>Application</b>
Choline	Choline kinase	Brain tumors, prostate, lung and esophageal cancer
DASB	SERT receptors	Neuropsychiatric disorders
Flumazenil	Benzodiazepine receptor	Neurodegenerative diseases
Methionine	Amino acid transporter	Brain, head and neck, lung and breast cancer, lymphomas
PIB	Alzheimer disease	Neuropsychiatric disorders
PHNO	D <sub>3</sub> dopamine receptors	Neuropsychiatric disorders
Raclopride	D <sub>2</sub> dopamine receptors	Neuropsychiatric disorders
Thymidine	Thymidine kinase-1	Tumor proliferation

### Specifications:

**Yields:** > 50 % for [<sup>11</sup>C]CH<sub>3</sub>I in less than 7 min

**Total activity is dependent on the produced [<sup>11</sup>C]CO<sub>2</sub>, which means it is dependent on the cyclotron.**

**Yields and specific activity of labeled [<sup>11</sup>C]tracers are dependent on use of proper technique and appropriate reagents.**

Time for sequential synthesis	Depends on the selected synthesis
Number of consecutive [ <sup>11</sup> C]CH <sub>3</sub> I syntheses	10, then exchange of NaOH trap
Dimensions	65 × 48 × 48 (w × d × h in cm)
Weight	Approx. 48 kg

**Hot Cell (minimum size)** 75 × 55 × 55 (w × d × h in cm)

### Utilities

Compressed air	4 - 8 bar 6 mm O.D.
Compressed He	Purity 6.0 (99.9999 %) 3 - 5 bar, 1/8" O.D.
Compressed H <sub>2</sub>	Purity 6.0 (99.9999 %) 3 bar, 1/16" O.D.
Target gas connection	1/8" O.D.