

## Synthra Melplus Reaction Loop (Catalog No. 003I)

Synthra MeIplus Reaction Loop is a flexible and completely automated radiosynthesizer for the efficient production of [ $^{11}\text{C}$ ]-labeled compounds based on the generation of gas-phase production of [ $^{11}\text{C}$ ]methyl iodide and [ $^{11}\text{C}$ ]methyl triflate. Automating the synthesis is simple with the easy-to-use configuration software SynthraView. The Synthra MeIplus Reaction Loop module offers both fully automatic and manual modes of operation.

### Gas Phase Capabilities

- ✓ High specific activities are achieved from in-target produced [ $^{11}\text{C}$ ]CO<sub>2</sub> ranging from 5 Ci/ $\mu\text{mol}$  to 20 Ci/ $\mu\text{mol}$  (Higher specific activities are possible when using methane target).

The [ $^{11}\text{C}$ ]CO<sub>2</sub> produced in target is quantitatively trapped in the stainless steel capillary tubing at -180 °C. Subsequently, the [ $^{11}\text{C}$ ]CO<sub>2</sub> is released into the methane oven where it is converted to [ $^{11}\text{C}$ ]CH<sub>4</sub> by reduction on a Ni-catalyst. The [ $^{11}\text{C}$ ]CH<sub>4</sub> is trapped at -120 °C on Carboxen®. In a successive gas phase reaction the iodination of [ $^{11}\text{C}$ ]CH<sub>4</sub> to [ $^{11}\text{C}$ ]MeI is carried out in a gas phase recirculation system with gaseous I<sub>2</sub> at 730 °C. During circulation [ $^{11}\text{C}$ ]MeI accumulates on a Porapak™ column. Finally, it is released at 200°C and ready for any kind of labeling reaction.

### [ $^{11}\text{C}$ ] Labeling Possibilities

- **[ $^{11}\text{C}$ ]Methyl iodide production:** [ $^{11}\text{C}$ ]MeI is ready for release 7 minutes after trapping the [ $^{11}\text{C}$ ]CO<sub>2</sub>. The yield for the [ $^{11}\text{C}$ ]methyl iodide formation is under good conditions above 50 % non-decay corrected (ndc).
  - Up to 10 sequential methyl iodide preparations are possible from a single box set-up.
- ✓ **Methyl triflate production:** The [ $^{11}\text{C}$ ]MeI can be converted to [ $^{11}\text{C}$ ]MeOTf by passing through a silver triflate filled column at 180 °C. The possible conversion yield from methyl iodide is 95 %.
- The [ $^{11}\text{C}$ ]methyl iodide or [ $^{11}\text{C}$ ]methyl triflate can either be directed into **the loop for homogeneous captive chemistry reactions** developed by Alan Wilson or can be used for **solid support reactions** for the synthesis of e.g. [ $^{11}\text{C}$ ]methionine.



- Under good conditions, the **conversion efficiency** of the loop system can be better than 95 %. Labeling efficiency is depending on the quality of the precursor solution.
- ✓ **Acetate production:** The purified [ $^{11}\text{C}$ ]CO<sub>2</sub> is passed into the reaction loop for Grignard reactions.

### General Features

- ✓ **Heating and cooling capabilities**
  - Eight heating zones
  - Five with cooling capabilities
  - Temperature range: -196 °C – 950 °C
- ✓ **Detectors and controllers**
  - Six shielded radiation detectors
  - Three electronic flow controllers
  - Two Pressure sensors
- ✓ **Dispensers and valves**
  - HPLC pneumatic injection valve (1.5 mL sample loop)

# Synthra C-11 Family

## Product Description and Technical Specifications



- Three spare valves for customization
- Chemically inert valves with small dead volume < 35 µL, 5 bar rated
- ✓ **Dimensions** (w x d x h): 52 × 50 × 48 cm
- ✓ **Weight:** approx. 40 kg

### Synthesis Features

- ✓ **Capillary reaction loop** with integrated cooling (-196 °C – 200 °C) to reduce synthesis time
- ✓ **Triflate/column oven** (RT – 200 °C)
- ✓ **Five reagent vials**
  - Three small (1 – 3 mL) and two large (10 – 15 mL) volume glass vials for reagents
- ✓ **One additional cartridge holder**
- ✓ **Built-in preparative radio/UV-HPLC system** with isocratic pump for in-process purification and final product collection (max flow: 40 mL/min)
  - Fixed wavelength LED detector with 255 nm or 280 nm
  - One HPLC semi-preparative column

- ✓ **SPE unit** for final product formulation
- ### Additional Synthesis Options

- ➔ **Product solvent evaporator** (Catalog No. 000pse)
- ➔ **Variable wavelength UV detector** (Catalog No. 000vuv)
- ➔ **Quaternary gradient pump** (Catalog No. 000qgp)

### GMP Features

- ✓ Synthesis files for several tracers are available
- ✓ **GMP compliant.** Electronic control and data collection (27/18 channels)
- ✓ **21CFRpart11** & **LIMS** compatible

### Terminal Control

- ✓ A laptop (Win 10 Pro) with preinstalled controlling software SynthraView is included
- ✓ Four digital inputs for communication with external devices upon request

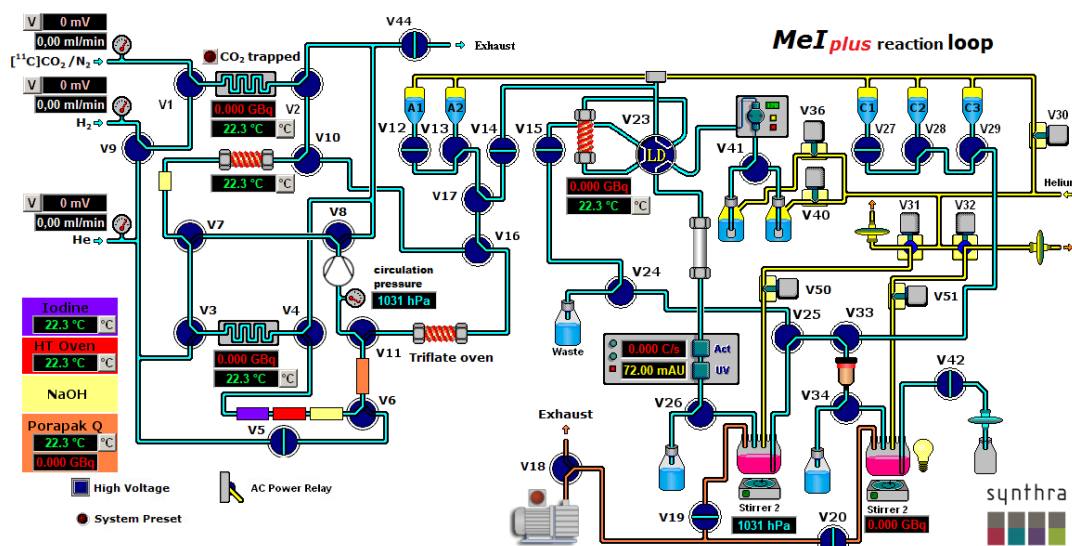

The Graphical User Interface (GUI) of the SynthraView software.