

## Synthra MeIplus Research (Catalog No. 003r)

Synthra MeIplus Research is a flexible and completely automated radiosynthesizer for the efficient production of [ $^{11}\text{C}$ ]labeled compounds based on the generation of gas-phase production of [ $^{11}\text{C}$ ]methyl iodide and [ $^{11}\text{C}$ ]methyl triflate. It is specially designed to perform the required multi-step synthesis e. g. for using [ $^{11}\text{C}$ ]propylation. Automating the synthesis is simple, with the easy-to-use configuration software SynthraView. The Synthra MeIplus Research module offers both fully automatic and manual modes of operation.

### Gas Phase Capabilities

- ✓ High specific activities are achieved from in-target produced [ $^{11}\text{C}$ ]CO<sub>2</sub> ranging from 5 Ci/ $\mu\text{mol}$  to 20 Ci/ $\mu\text{mol}$  (Higher specific activities are possible when using methane target).

The [ $^{11}\text{C}$ ]CO<sub>2</sub> produced in target is quantitatively trapped in the stainless steel capillary tubing at -180 °C. Subsequently, the [ $^{11}\text{C}$ ]CO<sub>2</sub> is released into the methane oven where it is converted to [ $^{11}\text{C}$ ]CH<sub>4</sub> by reduction on a Ni-catalyst. The [ $^{11}\text{C}$ ]CH<sub>4</sub> is trapped at -120 °C on Carboxen®. In a successive gas phase reaction the iodination of [ $^{11}\text{C}$ ]CH<sub>4</sub> to [ $^{11}\text{C}$ ]MeI is carried out in a gas phase recirculation system with gaseous I<sub>2</sub> at 730 °C. During circulation [ $^{11}\text{C}$ ]MeI accumulates on a Porapak™ column. Finally, it is released at 200°C and ready for any kind of labeling reaction.

### [ $^{11}\text{C}$ ] Labeling Possibilities

- **[ $^{11}\text{C}$ ]Methyl iodide production:** [ $^{11}\text{C}$ ]MeI is ready for release 7 minutes after trapping the [ $^{11}\text{C}$ ]CO<sub>2</sub>. The yield for the [ $^{11}\text{C}$ ]methyl iodide formation is under good conditions above 50 % non-decay corrected (ndc).
  - Up to 10 sequential methyl iodide preparations are possible from a single box set-up.
- ✓ **Methyl triflate production:** The [ $^{11}\text{C}$ ]MeI can be converted to [ $^{11}\text{C}$ ]MeOTf by passing through a silver triflate filled column at 180 °C. The possible conversion yield from methyl iodide is 95 %.
  - Both [ $^{11}\text{C}$ ]MeI and [ $^{11}\text{C}$ ]MeOTf can be used for solid support heterogeneous reactions (e. g. [ $^{11}\text{C}$ ]choline, [ $^{11}\text{C}$ ]methionine) or can be released into the reaction vessel for homogeneous reactions.
- ✓ **Acetate production:** The purified [ $^{11}\text{C}$ ]CO<sub>2</sub> is passed into the reaction vessel for Grignard reactions.

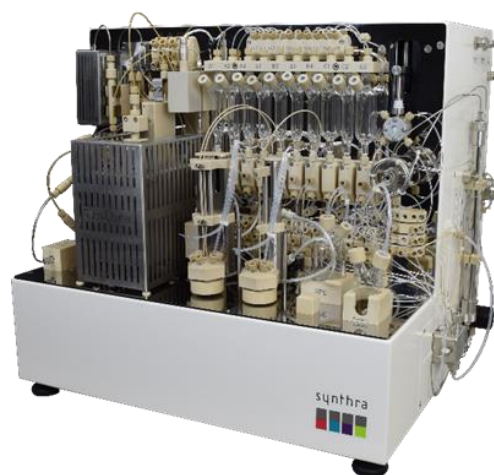

### General Features

- ✓ **Heating and cooling capabilities**
  - Nine heating zones
  - Six with cooling capabilities
  - Temperature range: -196 °C – 950 °C
- ✓ **Detectors and controllers**
  - Six shielded radiation detectors
  - Three electronic flow controllers (HCN option: Four flow controllers)
  - Four Pressure sensors
- ✓ **Dispensers and valves**
  - HR-dispenser (up to 50.000 steps, 2.5/5 mL)
  - HPLC pneumatic injection valve (0.5 mL to 2.5 mL sample loop)
  - Five spare valves for customization
  - Chemically inert valves with small dead volume < 35  $\mu\text{L}$ , 5 bar rated
- ✓ **Self-Cleaning System**
- ✓ **Dimensions** (w x d x h): 55 x 50 x 48 cm

# Synthra C-11 Family

## Product Description and Technical Specifications

synthra



- ✓ **Weight:** approx. 40 kg

### Synthesis Features

- ✓ **Two closed reaction vessel** (-196 °C – 200 °C) with integrated cooling to reduce synthesis time
  - 3 mL reaction vessel (minimum volume: 50 µL)
- ✓ **Triflate/column oven** (RT – 200 °C)
- ✓ **Ten reagent vials**
  - Eight small (1 – 3 mL) and two large (10 – 15 mL) volume glass vials for reagents
- ✓ **Three additional cartridge holders**
- ✓ **Built-in preparative radio/UV-HPLC system** for in-process purification and final product collection (max flow: 40 mL/min)
  - Variable wavelength detector with a range from 190 nm to 900 nm
  - Quaternary gradient
  - One HPLC semi-preparative column
- ✓ **SPE unit** for final product formulation

### Additional Synthesis Options

- ➔ **[<sup>11</sup>C]CO option** (Catalog No. 003co): After purification, the [<sup>11</sup>C]CO<sub>2</sub> is released into the column oven for Zn- or Mo-catalyzed reduction to [<sup>11</sup>C]CO.

- ➔ **[<sup>11</sup>C]HCN option** (Catalog No. 003hcn): The [<sup>11</sup>C]CH<sub>4</sub> is released with NH<sub>3</sub> gas into a high temperature area where it undergoes a Pt-catalyzed conversion into [<sup>11</sup>C]HCN at 950 °C.
- ➔ **[<sup>11</sup>C]HCN/CO option** (Catalog No. 003hcnc): This option combines all features of the HCN and the CO option
- ➔ **Loop option** (Catalog No. 003lo): A heatable and coolable reaction loop is integrated in the synthesis route to reduce synthesis time.
- ➔ **Product solvent evaporator** (Catalog No. 000pse)

### GMP Features

- ✓ Synthesis files for several [<sup>11</sup>C]radiotracers available
- ✓ **GMP compliant.** Electronic control and data collection (27/18 channels)
- ✓ **21CFRpart11** & **LIMS** compatible

### Terminal Control

- ✓ A laptop (Win 10 Pro) with preinstalled controlling software SynthraView is included
- ✓ Four digital inputs for communication with external devices upon request

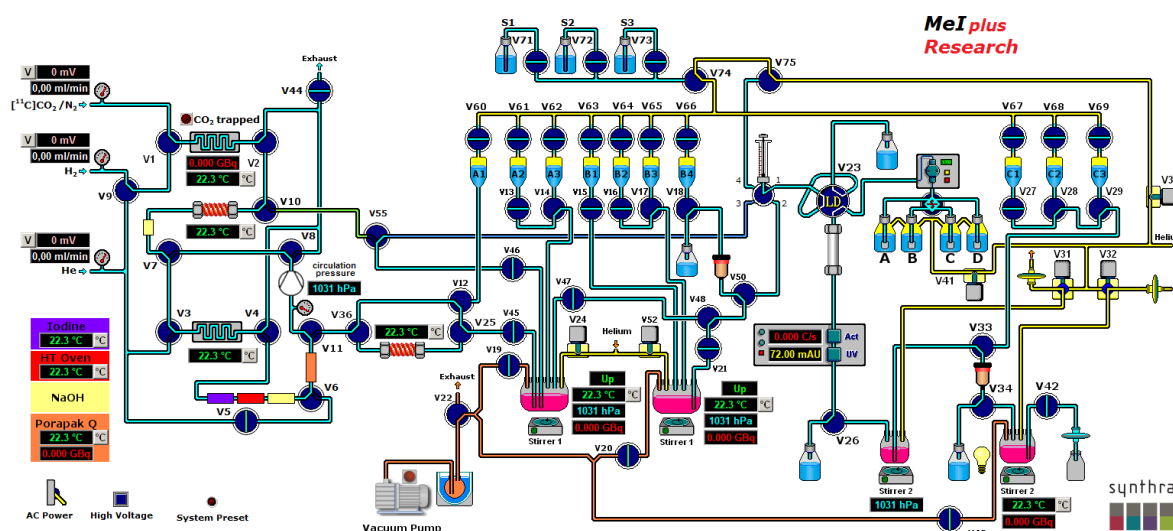

The Graphical User Interface (GUI) of the SynthraView software.